

United States Court of Appeals for the Federal Circuit

TELEFONAKTIEBOLAGET LM ERICSSON,
Appellant

v.

**TCL CORPORATION, TCL COMMUNICATION
TECHNOLOGY HOLDINGS LIMITED, TCT
MOBILE LIMITED, TCT MOBILE, INC., TCT
MOBILE (US) INC.,**
Appellees

2017-2381, 2017-2385

Appeals from the United States Patent and Trademark
Office, Patent Trial and Appeal Board in Nos. IPR2015-
01584, IPR2015-01600.

Decided: November 7, 2019

DEBRA JANECE MCCOMAS, Haynes & Boone, LLP, Dal-
las, TX, argued for appellant. Also represented by J.
ANDREW LOWES, CLINT S. WILKINS, Richardson, TX.

JULIE S. GOLDEMBERG, Morgan, Lewis & Bockius LLP,
Philadelphia, PA, argued for appellees. Also represented
by WILLIAM R. PETERSON, Houston, TX; NATHAN W.
MCCUTCHEON, BRADFORD CANGRO, Washington, DC.

Before NEWMAN, LOURIE, and CLEVINGER, *Circuit Judges*.
NEWMAN, *Circuit Judge*.

Telefonaktiebolaget LM Ericsson (“Ericsson”) is the owner of United States Patent No. 6,029,052 (“the ’052 patent”). TCL Corporation, TCL Communication Technology Holdings, Ltd., TCT Mobile Limited, TCT Mobile Inc., and TCT Mobile (US), Inc., (collectively “TCL”) filed two petitions for inter partes review (“IPR”) of claims 13, 15, 16, and 18 of the ’052 patent. The Patent Trial and Appeal Board (“PTAB” or “Board”) instituted review, consolidated the petitions, and ruled that all of the challenged claims are unpatentable on the ground of obviousness.¹

The ’052 patent describes and claims a “direct conversion receiver” for wireless communication systems that may receive signals from systems that operate at different frequency bands. The primary issue on appeal is whether a specific foreign publication is an available reference against the ’052 patent. We affirm the Board’s decision that the specified publication is an available reference, and based on this publication in combination with other prior art we affirm the Board’s decision of invalidity of the challenged claim.

The Ericsson ’052 Patent

The method claimed in the ’052 patent is stated to be an improvement over conventional modes of receiving and processing wireless signals from communication systems that operate at differing frequencies. Such systems previously required separate receiver components to process signals arriving at differing frequencies. The ’052 patent claims a method whereby receivers “can receive signals at

¹ *TCL Corp. v. Telefonaktiebolaget LM Ericsson*, IPR2015-01584 and IPR2015-01600, 2017 WL 504682, (P.T.A.B. Jan. 24, 2017) (“Board Op.”).

multiple frequency bands without requiring significant hardware duplication.” ’052 patent, col. 2, ll. 3–28.

Claim 18 is at issue on appeal, shown with claim 13 from which it depends:

13. A method for receiving a communication signal, comprising the steps of:

receiving a communication signal in any one of a plurality of frequency bands, the communication signal having a bandwidth;

band-pass filtering the received communication signal;

amplifying the band-pass filtered signal;

mixing the band-pass filtered signal with in-phase and quadrature oscillator signals to generate an in-phase and a quadrature received signal; and

low pass filtering the in-phase received signal and the quadrature received signal in a low pass in-phase filter and a low pass quadrature filter, respectively,

wherein direct conversion is used for converting all received communication signals in any one of the plurality of frequency bands.

18. The method of claim 13, further comprising the steps of generating a first oscillator signal and frequency-dividing the first oscillator signal to generate the in-phase and quadrature oscillator signals prior to the step of mixing.

Patent Figure 3 depicts the method of the ’052 patent:

FIG. 3

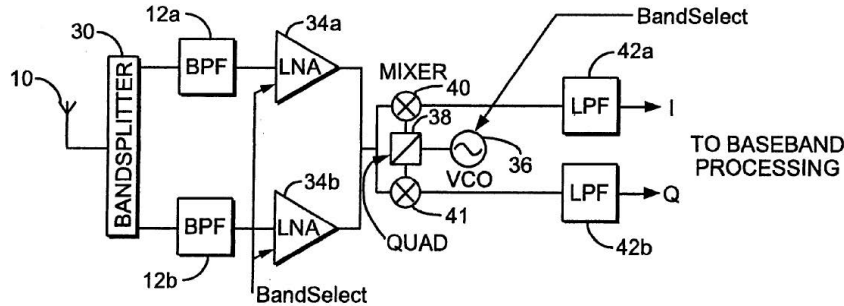

The specification explains that wireless signals are received at antenna 10, and bandsplitter 30 splits the signals into two frequency bands. The split signals are filtered by band pass filters (BPF), shown at 12a and 12b, to remove out-of-band unwanted components that are frequency band specific. The filtered signals are amplified by low-noise amplifiers (LNA) shown at 34a and 34b. The signals proceed to a mixing circuit that includes a voltage-controlled oscillator (VCO) 36 for generating an oscillator signal. A quadrature² generator 38 separates the oscillator signal into in-phase (I) and quadrature (Q) components.

Frequency phase shifting is conducted by either the quadrature generator 38 or a frequency divider that generates quadrature local oscillator signals. The phase shifter receives the signal from a local oscillator and outputs two signals separated by 90 degrees. These divided signals are sent to mixers 40 and 41, which compare the divided signals against the received signal. The signals are filtered in an in-phase low pass filter 42a and a quadrature low pass filter 42b, and the filtered signals are passed to conventional baseband processing circuitry. '052 patent, col. 3, ll. 9–28; col. 4, ll. 10–23.

² “Quadrature” means 90 degrees out of phase.

The principal reference presented by petitioner TCL and relied on by the PTAB is an article entitled “Multimodale Funktelefone” (translation: Multimodal Wireless Telephones), authored by Professor Hans-Joachim Jentschel *et al.* and published in the German technical journal “Ingenieur der Kommunikationstechnik” (translation: Engineer of Communications Technology). The initial question is whether this article is available as prior art.

I

The Jentschel Article

Ericsson argues that the Jentschel article is not prior art because it was not publicly available more than one year before Ericsson’s earliest asserted filing date, and thus is subject to antedating by Ericsson’s invention date. Ericsson alternatively argues that even if Jentschel is deemed to be prior art, the challenged claim is not obvious in view thereof.

A. Date of the Reference

The Jentschel article was published in a German periodical whose cover states the date “Mai/Juni” 1996, as follows:



J.A. 2377. May/June 1996 is more than one year earlier than Ericsson’s filing date of July 1, 1997. However, it was

shown that this journal issue did not reach the UCLA library until October 1996. Ericsson argued that “Dates alone on a document are insufficient as a matter of law to establish public accessibility.” Patent Owner’s Response at 13.

TCL sought to provide evidence of the date of availability of this journal issue in university libraries in Germany. On October 8, 2015 TCL submitted to the PTAB a letter from a librarian who was described as a member of the “Periodicals Team” at the Technische Informationsbibliothek and Universitätsbibliothek in Hannover, Germany. The letter stated that the public had library access to the May/June 1996 issue on June 19, 1996. On March 1, 2016, Ericsson objected to the letter as inadmissible hearsay. This statement was withdrawn when the librarian declined to provide a sworn statement and declined to testify in the United States.

On July 18, 2016, TCL moved to submit the sworn Declaration of Doris Michel, a librarian at the Technische Universität Darmstadt in Germany. Ericsson objected, stating that the submission was not in compliance with the Board’s Rules. The Rules require a petitioner to present sufficient evidence, at the petition stage, to inform the patent owner of the issues to be presented, and PTO regulation 37 C.F.R. § 42.123(b) requires that a party who seeks to submit new or supplemental information more than one month after the date an IPR is instituted

must show why the supplemental information reasonably could not have been obtained earlier, and that consideration of the supplemental information would be in the interests-of-justice.

Ericsson states that TCL was not diligent in providing admissible information because TCL did not start to look for this declarant until after Ericsson filed its objections to the Jentschel article.

The Board held that the Michel Declaration met the regulatory standard, based on TCL's recitation of its difficulties in finding a witness with personal knowledge of these past events. TCL stated that "Doris Michel is the *only* individual TCL found who has personal knowledge of the record-keeping procedures used in 1996, was willing to sign a sworn declaration, *and* is willing to travel to the U.S. to be deposed." Mot. to File Suppl. Info., at 5 (emphases original).

Ericsson argues that the time consumed by searching for a witness does not meet the regulatory standard, citing *Ultratec, Inc. v. CaptionCall, LLC*, 872 F.3d 1267, 1272 (Fed. Cir. 2017) as holding that the standard for determining that evidence could not have been provided earlier requires showing that the evidence did not exist earlier. Ericsson states that the Board improperly allowed TCL to submit tardy evidence to attempt to establish the publication date, and that Ericsson was prejudiced by this delay, for it had been developing its defense against references that the Board discarded after it accepted Jentschel as the principal reference. Ericsson also states that due to the delay it lost the opportunity to amend its claims.

TCL responds that Regulation § 42.123(b) gives the Board discretion to accept a tardy submission and to consider the interest of justice. TCL argues that the Jentschel article is very close prior art and that Ericsson was allowed to file supplemental briefing and to depose Ms. Michel.

Our review of the Board's action is on the abuse of discretion standard. The Board stated that "consideration of the supplemental information would be in the interests of justice," granting the motion. Mot. to File Suppl. Info. Dec., at 8. The Board recognized the possible burden on Ericsson, and assured that Ericsson had the opportunity to depose Ms. Michel and to respond to the substance of the Jentschel reference.

We conclude that the Board did not abuse its discretion in admitting the Michel Declaration, for when the challenged evidence is reasonably viewed as material, and the opponent has adequate opportunity to respond and to produce contrary evidence, the interest of justice weighs on the side of admitting the evidence. *Cf. Genzyme Therapeutic Prods. Ltd. P'ship v. Biomarin Pharm. Inc.*, 825 F.3d 1360, 1366 (Fed. Cir. 2016) (“[T]he introduction of new evidence in the course of the [PTAB] trial is to be expected in *inter partes* review trial proceedings and, as long as the opposing party is given notice of the evidence and an opportunity to respond to it, the introduction of such evidence is perfectly permissible under the APA.”).

B. Public Accessibility of the Jentschel Reference

Ericsson argues that the date of availability to the public of the Jentschel reference was not established by the Michel Declaration, even if that Declaration is deemed admissible. A reference is deemed publicly available if it has been “disseminated or otherwise made available to the extent that persons interested and ordinarily skilled in the subject matter or art, exercising reasonable diligence, can locate it.” *Jazz Pharm., Inc. v. Amneal Pharm., LLC*, 895 F.3d 1347, 1355 (Fed. Cir. 2018). “Because there are many ways in which a reference may be disseminated to the interested public, ‘public accessibility’ has been called the touchstone in determining whether a reference constitutes a ‘printed publication’ . . .” *In re Hall*, 781 F.2d 897, 898–99 (Fed. Cir. 1986). Whether a reference is publicly accessible is a question of fact. *In re NTP, Inc.*, 654 F.3d 1279, 1296 (Fed. Cir. 2011).

The librarian Doris Michel declared that the journal *Ingenieur der Kommunikationstechnik* was in the collection of the Darmstadt Library “since Volume 13, which corresponds to the year 1963.” Board Op. at *6 (quoting Michel Decl. (translation) at 3). She declared that she worked at this Library in 1996, that Library records show

that the journal issue dated Mai/Juni 1996 was catalogued and shelved with the shelf call number Tech Z Fe 57, and the Mai/Juni 1996 issue that she now obtained from the Library bears such call number. Michel Decl. at 4. She declared that this issue “was inventoried by the Library on June 18, 1996 [and] was openly accessible for use to the public after a processing time of 1-2 days.” Michel Decl. at 4.

Doris Michel declared that her testimony was based on her review of the Library register, her personal knowledge of the Library’s registration practices, and the current condition of the Mai/Juni 1996 issue that was in the Library. Michel Decl. at 3. She provided copies of the index card (“Kardex sheet”) that recorded the Library’s accession of this journal and showed the Library’s entry for the issue identified as “Tech Z Fe 57;” she stated that this entry matches the sticker on the Library’s copy of the Mai/Juni 1996 issue. Michel Decl. at 4, 6. She also testified that the Kardex sheet itself was not publicly available. Michel Decl. at 4. The lack of public availability of the Kardex sheet was not shown to impede public access to the Jentschel reference after a processing time of 1-2 days.

The Board found as fact that the Jentschel article was received and shelved in the Darmstadt library in May/June 1996. The Board reasoned that “Here, the periodical issue was housed in a library accessible to the public, published in a periodical that had been published for more than thirty years, and presumably articles within an issue were treated as a public disclosure of information.” Board Op. at *6. *See also Blue Calypso, LLC v. Groupon, Inc.*, 815 F.3d 1331, 1348 (Fed. Cir. 2016) (the criterion is whether the publication was publicly available “to the extent that persons interested and ordinarily skilled in the subject matter or art exercising reasonable diligence, can locate it”) (quoting *Kyocera Wireless Corp. v. Int’l Trade Comm’n*, 545 F.3d 1340, 1350 (Fed. Cir. 2008)).

Ericsson argues that “precedent requires something more than simply shelving the document in a library.” Reply Br. 2. Ericsson argues that the only evidence of public availability is the Kardex sheet of the Darmstadt Library, and that this is insufficient support for the Board’s ruling that the Jentschel article was publicly accessible in May/June 1996. TCL responds that the Michel Declaration constituted substantial evidence of public availability in the Darmstadt Library.

Ericsson states that the Board improperly placed on Ericsson the burden of proving the date of availability of the Jentschel article. Ericsson is correct that it did not bear the ultimate burden of proof, for the proponent of a foreign publication bears the burden of proving its availability if challenged. However, Ericsson provided no evidence to counter the Michel Declaration, the date on the face of the journal, and the Library’s records showing receipt of the journal and its shelving.

This case is unlike cases in which a single dissertation or thesis was housed in a library, *e.g.*, *In re Bayer*, 568 F.2d 1357 (CCPA 1978) (applicant’s uncatalogued, unshelved master’s thesis was not publicly accessible); *In re Cronyn*, 890 F.2d 1158, 1161 (Fed. Cir. 1989) (student undergraduate theses were not publicly accessible because “they had not been either cataloged or indexed in a meaningful way”).

Ericsson does not dispute that this journal had been published for at least thirty years and that the library was accessible to the public. *See GoPro, Inc. v. Contour IP Holding LLC*, 908 F.3d 690, 693–95 (Fed. Cir. 2018) (“[I]nterested members of the relevant public could obtain the information if they wanted to.”). *Cf. Voter Verified, Inc. v. Premier Election Sols., Inc.*, 698 F.3d 1374, 1380 (Fed. Cir. 2012) (the reference was available on-line and although not meaningfully indexed it was publicly accessible because the publication was well known to persons interested in the subject matter).

Substantial evidence supports the Board’s ruling that Jentschel was accessible to the public in the May/June 1996 period. The Board did not abuse its discretion in receiving the Jentschel article as a reference.

II

Obviousness

We give plenary review to the Board’s legal determination of obviousness; the Board’s underlying factual findings are reviewed for support by substantial evidence. *In re Gartside*, 203 F.3d 1305, 1316 (Fed. Cir. 2000) (applying the standards of the Administrative Procedure Act to PTO findings and conclusions). Substantial evidence is “such relevant evidence as a reasonable mind might accept as adequate to support a conclusion.” *Consol. Edison Co. v. NLRB*, 305 U.S. 197, 229 (1938).

The Board held that the Jentschel article, taken together with Japanese patent application JP947 in IPR2015-01594, or together with JP947 and Japanese patent application JP755 in IPR2015-01600, renders claim 18 invalid for obviousness.

The Jentschel Article

The Jentschel article discusses the problem presented by wireless systems operating at differing frequencies, and communication networks operating on differing standards, such as are used by cellular and wireless phone systems. Jentschel states that “the user would have to carry at least two different cell phones.” Board Op. at *13 (quoting Jentschel (translation) at 1). Jentschel presents the solution of using a system that has a transceiver “the operating mode of which can be switched to different standards.” *Id.* (quoting Jentschel at 3–4). Jentschel describes a “multimode direct-mixing receiver,” and depicts a “block wiring diagram of a direct-mixing receiver (Direct Conversion Receiver or DCR, zero-IF receiver) used as [a] multimode receiver.” *Id.* (quoting Jentschel at 7, 10–13).

The expert witnesses for both TCL and Ericsson agreed that Jentschel’s direct-mixing receiver is described as converting a received “HF [high frequency] signal in one step (directly) to the low-frequency complex baseband signal by means of a quadrature mixer pair. . . . [T]he mixers are controlled by a complex LO [local oscillator].” *Id.* (quoting Jentschel at 7). The experts agreed that after quadrature mixing, the channel is selected by two low pass filters. Jentschel states the advantages of using a direct conversion receiver. Jentschel at 8–9.

The Jentschel article was found by the Board to show the claim 18 limitation of “frequency dividing the oscillator signal.” In IPR2015-01594, the Board cited the phase shifter shown in Jentschel’s figure 2, along with Jentschel’s identification of a frequency divider as a possible phase shifter. In IPR2015-01600, the Board cited the phase shifter in JP947, and found it would have been obvious to “implement JP947’s phase shifter as a frequency divider” based on Jentschel’s teachings. Board Op. at *31–32. The Board found that Jentschel discloses all of the elements of claim 18. As summarized by TCL:

Jentschel explains the need for multimode cell phones, with “one transceiver . . . , the operating mode of which can be switched to different standards.” Direct conversion receivers minimize duplication of components: In a direct conversion multimode receiver, “[e]xcept for the antenna and the system filter, . . . the entire receiver part is completely integrable.” Because of these advantages, “[t]he concept of the direct-mixing receiver is thus predestined for use in multimode cell phones.”

It is undisputed that Jentschel explains that frequency dividers can be used as phase shifters, along with some advantages and disadvantages of doing so: “[B]roadband phase shifters can be assembled by means of frequency dividers The

high phase accuracy and the constant amplitude ratio are advantageous However, the high power demand is disadvantageous.”

It is also undisputed that Jentschel discloses resistive-capacitive (RC) phase shifters as another option that is “suitable” in at least some circumstances.

TCL Br. 13 (citations omitted).

Ericsson argues that Jentschel is a mere feasibility study and not enabled. Ericsson points out that although Jentschel mentions frequency dividers it does not require the use of frequency dividers as a phase shifter, but discloses RC [resistive-capacitive] phase shifters and conducting elements, as well as frequency dividers, for use as possible phase shifters.

The Board considered the arguments, and found that Jentschel “express[ly] indicat[es] that phase shifters can be implemented using frequency dividers,” Board Op. at *24, and that “although Jentschel identifies advantages and disadvantages of using a frequency divider, Jentschel does not criticize, discredit or discourage the use of a frequency divider.” *Id.* at *25. The Board referred to Jentschel Figure 2, which shows a phase shifter, and the passage discussing phase shifters that states frequency dividers are a possible phase shifter. The Board found that even if Jentschel’s Figure 2 is viewed as showing an RC phase shifter, not a frequency divider, these alternatives are described by Jentschel as known alternatives serving the same function.

In response to Ericsson’s argument that Jentschel does not provide the requisite motivation to select a frequency divider to shift phases, the Board observed that Jentschel expressly describes three possible phase shifters: (1) conducting elements (2) frequency dividers and (3) RC phase shifters. *Id.* at *24–25. The Board found that Jentschel

teaches “broadband phase shifters can be assembled by means of frequency dividers, whereby one divider each for the I and Q channel is controlled with twice the LO frequency and clocked by opposite edges.” *Id.* at *24 (quoting Jentschel at 10). The Board found that the phase shifter and the frequency divider are taught in Jentschel for the same purpose as in the ’052 patent.

The Board also found that a skilled artisan would have reason to “implement JP947’s phase shifter as a frequency divider, in order to generate accurate, frequency independent I and Q [local oscillator] signals with a small, integrable footprint, while minimizing statistical variations.” *Id.* at *32.

Ericsson states that Jentschel “teaches away” from the potential use of a frequency divider because Jentschel states “the high power demand is disadvantageous.” Jentschel at 10. Ericsson states that “if a frequency divider is used, the local oscillator (LO) generates a signal at a frequency that is twice the center of the radio signal to be received,” and that the use of a frequency divider is incompatible with the teachings of Jentschel. Ericsson Br. 44 (emphasis in original). TCL responds that Figure 2 of Jentschel provides the motivation to use, or at least renders it obvious to try, a frequency divider, for Figure 2 of Jentschel does not specify the type of phase shifter in its block diagram of a “direct-mixing receiver (Direct Conversion Receiver or DCR, zero-IF receiver) used as [a] multi-mode receiver.” (Jentschel at 7).

The Jentschel teaching is as follows:

The phase shifter provides the mixer of the Q channel with an LO signal which is phase-shifted relative to the I signal. Phase shifters on the basis of conducting components have dimensions in the frequency range below 2 GHz which prevent integration. However, broadband phase shifters can be assembled by means of frequency dividers,

whereby one divider each for the I and Q channel is controlled with twice the LO frequency and clocked by opposite edges. The outputs subsequently generate two signals phase-shifted by 90°. The high phase accuracy and the constant amplitude ratio are advantageous, so no adjustment to the respective receive frequency is required during multimode operation. However, the high power demand is disadvantageous.

Jentschel at 10. The Board found that this passage teaches the use of frequency dividers to assemble phase shifters. Board Op. at *24.

Ericsson argues that Jentschel does not teach that frequency dividing should be used, because Jentschel discusses the disadvantages as well as advantages of using a frequency divider. Ericsson states that “Jentschel as a whole discloses . . . that RC phase shifters are preferred over frequency dividers.” Ericsson Br. 46. Ericsson argues that Jentschel is fairly read as teaching away from use of frequency dividers as a preferred solution.

The Board found that Jentschel’s statement concerning high power demand as a disadvantage of frequency dividers was not a “teaching away,” for Jentschel states that “phase shifters can be assembled by means of frequency dividers.” Board Op. at *24 (quoting Jentschel at 10). Jentschel’s Figure 2 does not indicate a specific form of phase shifter. The Board found that “We do not agree that Jentschel’s discussion of advantages and disadvantages of using a frequency divider or indicating that another component is suitable rises to the level of a teaching away.” *Id.* at *25.

The Board correctly summarized the general rule that a reference teaches away “when a person of ordinary skill, upon reading the reference, would be discouraged from following the path set out in the reference, or would be led in a direction divergent from the path that was taken by the

applicant.” *Id.* (quoting *In re Mouttet*, 686 F.3d 1322, 1333–34 (Fed. Cir. 2012)). The Board found that although Jentschel recites the disadvantage of the high power demand of frequency dividers, Jentschel does not suggest that this mode of phase shifting would be ineffective in achieving the high phase accuracy required of frequency dividers. Jentschel does not criticize, discredit, or discourage the technological efficacy of a frequency divider for phase shifting. *Id.*

We conclude that substantial evidence supports the Board’s finding that Jentschel renders obvious the claim 18 “steps of generating a first oscillator signal and frequency-dividing the first oscillator signal to generate the in-phase and quadrature oscillator signals prior to the step of mixing.” *Id.* at *24 (quoting claim 18).

The Japanese References

Japanese Application Publication No. H05-121947 (“JP947”), published May 18, 1993, describes “a direct conversion reception system . . . that amplif[ies], separately in multiple frequency bands, the weak high-frequency signal from a multiband antenna.” JP947 Abstract (Translation). Japanese Application Publication No. H5-160755 (“JP755”), published June 25, 1993 is similar in disclosure. The Board held in IPR2015-01584 that the Jentschel reference in view of JP947 renders obvious the subject matter of claim 18. The Board held in IPR2015-01600 that the Japanese references fill any perceived gap in rendering it obvious to use a frequency divider as the phase shifter.

The JP947 direct conversion system is described as applicable to FM broadcasting, AM broadcasting, and satellite broadcasting, and provides direct conversion among these systems. JP947 ¶ 16. The JP947 system includes a multiband antenna, an AM high-frequency amplifier, AM and FM high-frequency filters, a mixer that transforms the output signals of the FM filter and AM filters into an

orthogonal signal, and an oscillator for mixing the received signals and forming an orthogonal signal. *Id.* ¶ 12.

The Board held that the Jentschel article together with the JP947 system's phase shifter renders claim 18 obvious. Ericsson argues that the Japanese and the Jentschel references deal with different systems, and that the Board erred by selecting portions of Jentschel and combining a portion of the JP947 system. Ericsson Br. 46. Ericsson argues that there is no teaching or motivation in the references to combine these different embodiments. Ericsson also states that the Japanese references do not teach that a frequency divider could be used successfully.

The Board found that a skilled artisan would have been motivated to "implement JP947's phase shifter as a frequency divider, in order to generate accurate, frequency independent I and Q [local oscillator] signals with a small, integrable footprint, while minimizing statistical variations." Board Op. at *32. The Board stated that Jentschel's teachings would have motivated an artisan to do so because of "Jentschel's teachings of the advantages and the disadvantages associated with RC shifters, . . . [and] Jentschel's teaching that problems with generating in-phase and quadrature local oscillator signals using RC phase shifters can be overcome using a frequency divider." *Id.* at *31.

We conclude that substantial evidence supports the Board's findings and conclusions, whereby the subject matter of claim 18 would have been obvious. The Board's decisions in IPR2015-01584 and IPR2015-01600 are affirmed.

AFFIRMED

Each party shall bear its costs.